



# Cable Glands

## What Are They?

### Cable Glands

A cable gland is a device designed to attach and secure the end of an electrical cable to the equipment. Cable Glands address an essential requirement in cable management planning and implementation. Their foremost purpose is to grip and seal electrical cables where they pass through a dividing barrier, such as upon entry to a piece of equipment or where they pass through a bulkhead or panel. This is achieved by gripping either the outer sheath of the cable or the armour wire, or by a combination of the two. Cable glands are available in countless designs and features but these can be distilled down to four essential functions.

- **Sealing:** The ability to provide a barrier against ingress of dust, liquid or gas.
- **Retention:** The ability to secure and hold the cable in place, commonly known as 'pull out' resistance.
- **Continuity:** The ability to safely carry a peak short circuit current.
- **Environmental Protection:** The ability to protect against environmental attack, from corrosive or explosive liquids and gasses to ultraviolet exposure.

**Nylon 'Stuffing Gland'** - Perhaps the simplest type of gland, this comprises a body section, an outer sheath seal and a sealing nut. The complete assembly is secured to the equipment or panel via the threaded entry part; this can be threaded directly into the equipment if it has an existing receiving thread, or secured with a locknut if a blank hole. The cable can then be passed through the assembled gland and the sealing cap tightened, compressing the inner seal and securing the cable in place. This also provides an environmental seal around the outer sheath.

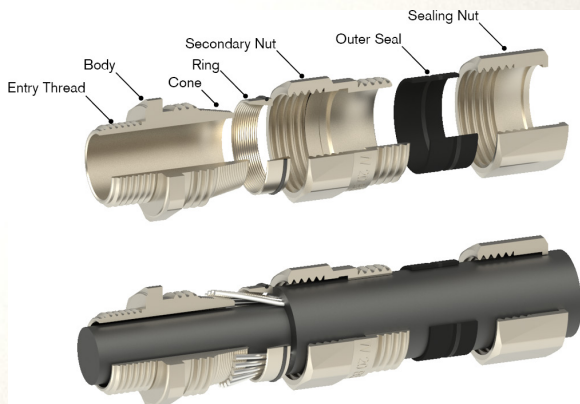
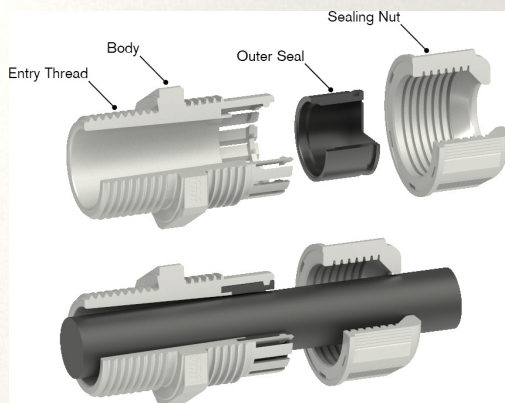

### CW type Steel Wire Armour gland

This gland is slightly more complex, because it needs to provide an additional connection to the cable armour, however it shares the same fundamental design. The entry thread of the body is used to secure the whole assembly to the equipment. A secondary threaded nut which houses a cone-and-ring assembly secures the cable armour to the gland and finally once again a sealing nut secures and provides an environmental seal against the outer sheath. There are several variations on this theme but nearly all cable glands work along this fundamental principal of a threaded entry assembly that connects to the equipment and additional threaded nuts which secure the cable to the assembly.